

## TPS7B67xx-Q1 450-mA High-Voltage Ultra-Low $I_Q$ Low-Dropout Regulator

### 1 Features

- Qualified for Automotive Applications
- AEC-Q100 Qualified With the Following Results
  - Device Temperature Grade 1:  $-40^{\circ}\text{C}$  to  $125^{\circ}\text{C}$  Ambient Operating Temperature Range
  - Device HBM ESD Classification Level H2
  - Device CDM ESD Classification Level C3B
- 4 to 40-V Wide- $V_{\text{IN}}$  Input-Voltage Range With up to 45-V Transient
- Maximum Output Current, 450 mA
- Low Quiescent Current ( $I_Q$ )
  - $< 4 \mu\text{A}$  When EN = Low (Shutdown Mode)
  - $15 \mu\text{A}$  Typical at Light Loads
- Low-ESR (0.001 to 20  $\Omega$ ) Ceramic Output-Stability Capacitor (10 to 500  $\mu\text{F}$  When  $V_O \geq 2.5 \text{ V}$ , 22 to 500  $\mu\text{F}$  when  $V_O = 1.5$  to 2.5 V)
- Maximum Dropout Voltage 450 mV at 400 mA
- Adjustable 1.5 to 18-V Output Voltages
- Low-Input Voltage Tracking to UVLO
- Integrated Power-On Reset
  - Programmable-Reset Pulse Delay
  - Open-Drain Reset Output
- Integrated Fault Protection
  - Thermal Shutdown
  - Short-Circuit Protection
- Packages
  - 20-Terminal HTSSOP
  - 5-Terminal DDPAK (Preview)

### 2 Applications

- Automotive
- Infotainment Tuner Supply
- Body Control Modules
- Always-ON Battery Applications
  - Gateway Applications
  - Remote Keyless Entry Systems
  - Immobilizers

### 3 Description

The TPS7B6701-Q1, TPS7B6733-Q1, TPS7B6750-Q1, TPS7B6750A-Q1, and TPS7B6750B-Q1 devices are low-dropout linear regulators designed for up to 40-V  $V_{\text{IN}}$  operations. With only 15- $\mu\text{A}$  quiescent current at light load which greatly increases the endurance time of the automotive battery, the devices drive loads up to 450 mA.

The TPS7B67xx-Q1 family of devices features an integrated short-circuit and overcurrent protection. Reset delay and power-good signal are implemented on power-up to indicate that the output voltage is stable and is in regulation. An external capacitor programs the delay. The enable function activates and deactivates the device with an I/O port from the MCU.

The device family operates at a temperature range of  $-40^{\circ}\text{C}$  to  $125^{\circ}\text{C}$ .

#### Device Information

ORDER NUMBER	PACKAGE	BODY SIZE
TPS7B6701QPWPRQ1	HTSSOP (20)	6,50 mm x 4,40 mm
TPS7B6733QPWPRQ1	HTSSOP (20)	6,50 mm x 4,40 mm
TPS7B6750QPWPRQ1	HTSSOP (20)	6,50 mm x 4,40 mm

### 4 Typical Application Schematic

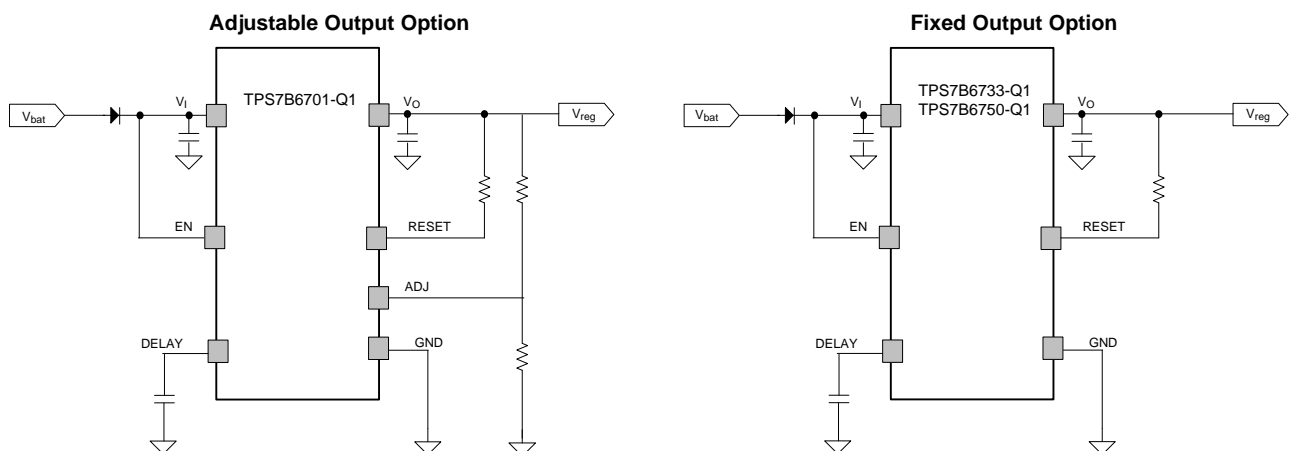

## Table of Contents

<b>1 Features</b> .....	<b>1</b>	8.2 Functional Block Diagram .....	<b>11</b>
<b>2 Applications</b> .....	<b>1</b>	8.3 Feature Description .....	<b>12</b>
<b>3 Description</b> .....	<b>1</b>	8.4 Device Functional Modes .....	<b>14</b>
<b>4 Typical Application Schematic</b> .....	<b>1</b>	<b>9 Application and Implementation</b> .....	<b>15</b>
<b>5 Revision History</b> .....	<b>2</b>	9.1 Application Information .....	<b>15</b>
<b>6 Terminal Configuration and Functions</b> .....	<b>4</b>	9.2 Typical Application .....	<b>15</b>
<b>7 Specifications</b> .....	<b>6</b>	<b>10 Power Supply Recommendations</b> .....	<b>17</b>
7.1 Absolute Maximum Ratings .....	<b>6</b>	<b>11 Layout</b> .....	<b>17</b>
7.2 Handling Ratings .....	<b>6</b>	11.1 Layout Guidelines .....	<b>17</b>
7.3 Recommended Operating Conditions .....	<b>6</b>	11.2 Layout Example .....	<b>18</b>
7.4 Thermal Information .....	<b>6</b>	<b>12 Device and Documentation Support</b> .....	<b>19</b>
7.5 Electrical Characteristics .....	<b>7</b>	12.1 Related Links .....	<b>19</b>
7.6 Timing Requirements .....	<b>8</b>	12.2 Trademarks .....	<b>19</b>
7.7 Typical Characteristics .....	<b>8</b>	12.3 Electrostatic Discharge Caution .....	<b>19</b>
<b>8 Detailed Description</b> .....	<b>11</b>	12.4 Glossary .....	<b>19</b>
8.1 Overview .....	<b>11</b>	<b>13 Mechanical, Packaging, and Orderable Information</b> .....	<b>19</b>

## 5 Revision History

NOTE: Page numbers for previous revisions may differ from page numbers in the current version.

Changes from Revision A (November 2013) to Revision B	Page
• Updated the first page by making the following additions: the <i>Device Information</i> table, device family name to document title, and added the navigation buttons .....	1
• Changed the $I_Q$ value from $< 2$ to $< 4$ when EN = Low in the <i>Features</i> list .....	1
• Added the <i>Table of Contents</i> and moved the <i>Revision History</i> to the second page .....	1
• Replaced the <i>ORDERING INFORMATION</i> table with the <i>Device Comparison</i> Table and deleted the Device and Package columns .....	4
• Changed KTT (B) terminal number for the ADJ terminal from 4 to — and the number for KTT (ADJ) from — to 4 .....	5
• Added Moved all electrical specifications tables and the <i>Typical Characteristics</i> section into the <i>Specifications</i> section .....	6
• Changed the max value for DELAY from $V_I$ to 45 V in the <i>Absolute Maximum Ratings</i> table. Also added new table note for DELAY .....	6
• Changed the max value for ADJ, RESET from $V_O$ to 22 V in the <i>Absolute Maximum Ratings</i> table .....	6
• Moved the ESD ratings (now $V_{ESD}$ ) and storage temperature into the <i>Handling Ratings</i> table. Added three ESD table notes .....	6
• Changed the value of $I_O$ from 1 mA to 450 mA for the Input voltage test conditions in the <i>Electrical Characteristics</i> table .....	7
• Added the value for $V_I$ in the test conditions of the Regulated output and the Line regulator parameters in the <i>Electrical Characteristics</i> table .....	7
• Moved the timing parameters (TIMING FOR RESET) out of the <i>Electrical Characteristics</i> table and into the new <i>Timing Requirements</i> table .....	8
• Added the <i>Overview</i> section title to the first paragraph of the <i>Detailed Description</i> section .....	11
• Updated the <i>Power-On_Reset (RESET)</i> section by making the following changes: changed the percentage that $V_O$ exceeds for the reset output to change from 90% to 91.6% (also changed this value in the <i>Reset Delay Timer (DELAY)</i> section), removed <i>The on-chip oscillator presets the delay</i> , and changed the percentage level to assert the output from 90% to 89.6% .....	12
• Changed the junction temperature value that disables thermal protection from 170°C to 175°C in the <i>Thermal Protection</i> section .....	14
• Added the <i>Device Functional Modes</i> section .....	14

## Revision History (continued)

• Added the <i>Typical Application</i> section in the new <i>Applications and Implementation</i> section .....	15
• Added the <i>Power Supply Recommendations</i> section .....	17
• Changed the <i>LAYOUT INFORMATION</i> section to the <i>Layout</i> section and added the <i>Layout Example</i> section .....	17
• Added the <i>Mechanical, Packaging, and Orderable Information</i> section. Also added the <i>Device and Documentation Support</i> section which now contains the trademark section and <i>Electrostatic Discharge Caution</i> . This section also includes a new reference to the TI Glossary .....	19

## Changes from Original (October 2013) to Revision A

Page

• Changed max dropout voltage from 500 mV to 450 mV in <i>FEATURES</i> list .....	1
• Added body control modules to <i>APPLICATIONS</i> list .....	1
• Changed the <i>low-voltage tracking</i> feature text to <i>enable function</i> text in the <i>DESCRIPTION</i> .....	1
• Changed document status from <i>Product Preview</i> to <i>Production Data</i> .....	1
• Changed TYPICAL APPLICATION SCHEMATIC to show difference between adjustable output and fixed output option .....	1
• Changed the MIN value for RESET and ADJ in the <i>RECOMMENDED OPERATING CONDITIONS</i> table from 0 to 1.5 and removed low voltage parameter for those pins .....	6
• Added Added board dimensions to the high K profile <i>THERMAL INFORMATION</i> table note .....	6
• Changed test condition for the input voltage to fixed 3.3-V output and added 5-V and two adjustable output conditions .....	7
• Changed max value for the line regulation parameter from 2 to 10 .....	7
• Changed TYP value for dropout voltage where $I_O = 400$ mA from 240 to 260 .....	7
• Changed TYP value for dropout voltage where $I_O = 200$ mA from 160 to 150 .....	7
• Changed Output current-limit typ value to max value for $V_{OUT}$ short to ground .....	7
• Deleted $V_{IN}$ condition from test condition for PSRR .....	7
• Added <i>TYPICAL CHARACTERISTICS</i> section .....	8
• Added the <i>DETAILED DESCRIPTION</i> section .....	11
• Added block diagram fro the TPS7B6733-Q1 and TPS7B6750-Q1 .....	11
• Added the <i>APPLICATION INFORMATION</i> section .....	15
• Added the <i>LAYOUT INFORMATION</i> section .....	17

### Device Comparison

ORDERABLE PART NUMBER	VOLTAGE OPTION (V <sub>OUT</sub> )
<b>HTSSOP</b>	
TPS7B6701QPWPRQ1	Adjustable 1.5 to 18 V
TPS7B6733QPWPRQ1	Fixed 3.3 V
TPS7B6750QPWPRQ1	Fixed 5 V
<b>DDPAK (Preview)</b>	
TPS7B6701QKTTRQ1	Adjustable 1.5 to 18 V
TPS7B6750AQKTTRQ1	Fixed 5 V
TPS7B6750BQKTTRQ1	Fixed 5 V

## 6 Terminal Configuration and Functions

20-Terminal HTSSOP  
PWP Package  
(Top View)

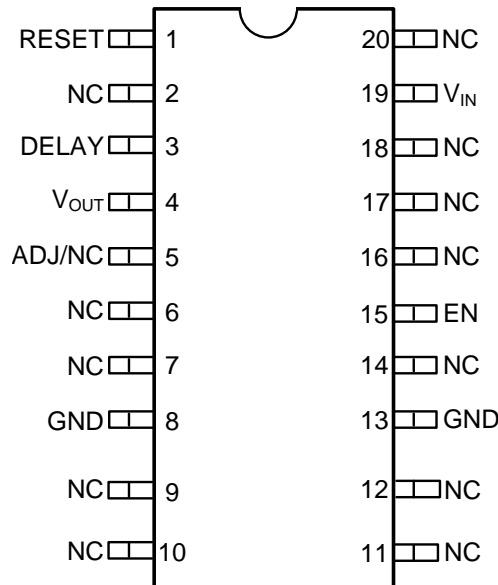

5-Terminal DDPK  
KTT Package  
Fixed Version A (Top View)

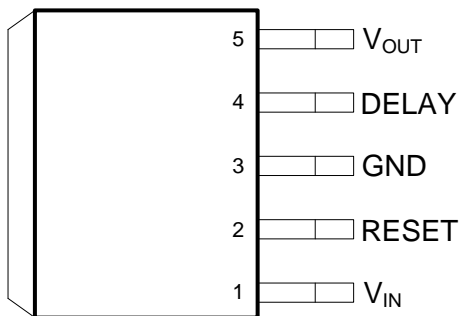

5-Terminal DDPK  
KTT Package  
Fixed Version B (Top View)

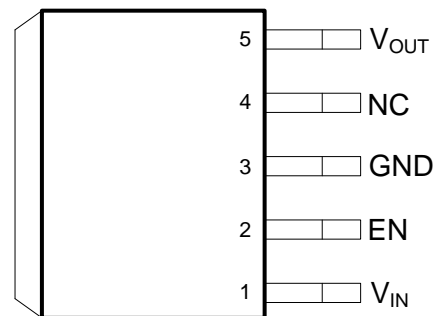

**5-Terminal DDPAK  
KTT Package  
Adjustable Version (Top View)**

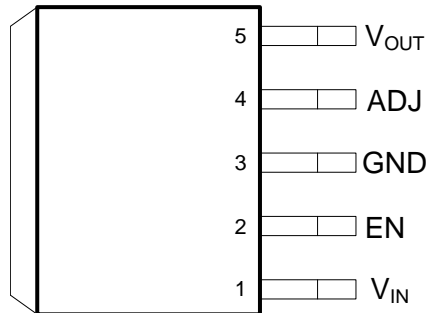

**Terminal Functions**

NAME	TERMINAL				TYPE	DESCRIPTION
	PWP	KTT (A)	KTT (B)	KTT (ADJ)		
ADJ	5	—	—	4	I	Feedback terminal. This terminal is used with an external resistor divider or the NC terminal when in a fixed version.
DELAY	3	4	—	—	O	Reset pulse delay adjustment. Connect this terminal through a capacitor to GND.
EN	15	—	2	2	I	Enable terminal. When the EN terminal becomes lower than threshold, the device enters the stand-by state.
GND	8	3	3	3	G	Ground reference
	13					
NC	2	—	4	—	—	Not connected
	6					
	7					
	9					
	10					
	11					
	12					
	14					
	16					
17						
18						
20						
RESET	1	2	—	—	O	Output ready. This open-drain terminal must be connected to V <sub>OUT</sub> through an external resistor. RESET is pulled down when the output voltage goes below threshold.
V <sub>IN</sub>	19	1	1	1	P	Input power-supply voltage
V <sub>OUT</sub>	4	5	5	5	P	Output voltage
PowerPAD™					—	PowerPad for the HTSSOP (PWP) and DDPAK (KTT) packages

## 7 Specifications

### 7.1 Absolute Maximum Ratings<sup>(1)</sup>

over operating free-air temperature range (unless otherwise noted)

		MIN	MAX	UNIT
Unregulated input range <sup>(2)(3)(4)</sup>	V <sub>IN</sub> , EN	-0.3	45	V
Output range	V <sub>OUT</sub>	-0.3	22	V
	DELAY <sup>(2)(3)(5)</sup>		45	V
	ADJ, RESET		22	V
Operating junction temperature range (T <sub>J</sub> )		-40	150	°C

- (1) Stresses beyond those listed under *absolute maximum ratings* may cause permanent damage to the device. These are stress ratings only and functional operation of the device at these or any other conditions beyond those indicated under *recommended operating conditions* is not implied. Exposure to absolute-maximum-rated conditions for extended periods may affect device reliability.
- (2) All voltage values are with respect to GND.
- (3) Absolute negative voltage on these terminals does not go below -0.3 V.
- (4) Absolute maximum voltage.
- (5) The voltage at the DELAY terminal must be lower than the V<sub>IN</sub> voltage.

### 7.2 Handling Ratings

		MIN	MAX	UNIT
T <sub>stg</sub>	Storage temperature range	-65	150	°C
V <sub>ESD</sub> <sup>(1)</sup>	Human body model (HBM), H2 <sup>(2)(3)</sup>		2	kV
	Charged device model (CDM), C3B <sup>(4)</sup>		750	V

- (1) Electrostatic discharge (ESD) to measure device sensitivity and immunity to damage caused by assembly line electrostatic discharges into the device.
- (2) The human body model is a 107-pF capacitor discharged through a 1.5-kΩ resistor into each terminal.
- (3) Level listed above is the passing level per ANSI/ESDA/JEDEC JS-001.
- (4) Level listed above is the passing level per EIA-JEDEC JESD22-C101.

### 7.3 Recommended Operating Conditions

over operating free-air temperature range (unless otherwise noted)

		MIN	MAX	UNIT
Unregulated input range	V <sub>IN</sub>	4	40	V
Output range	EN, DELAY	0	40	V
	V <sub>OUT</sub> , RESET, ADJ	1.5	18	V
T <sub>J</sub>	Operating junction temperature range	-40	150	°C

### 7.4 Thermal Information

THERMAL METRIC <sup>(1)(2)</sup>		TPS7B67xx-Q1		UNIT
		PWP (20 TERMINALS)	KTT (5 TERMINALS)	
θ <sub>JA</sub>	Junction-to-ambient thermal resistance	44.9	34.5	°C/W
θ <sub>JCtop</sub>	Junction-to-case (top) thermal resistance	27.4	38.9	
θ <sub>JB</sub>	Junction-to-board thermal resistance	23.6	20.3	
ψ <sub>JT</sub>	Junction-to-top characterization parameter	1.1	7.2	
ψ <sub>JB</sub>	Junction-to-board characterization parameter	23.4	18.6	
θ <sub>JCbot</sub>	Junction-to-case (bottom) thermal resistance	3.1	1.4	

- (1) The thermal data is based on JEDEC standard high K profile — JESD 51-7. Two signal, two plane, four-layer board with 2-oz copper. The copper pad is soldered to the thermal land pattern. Also correct attachment procedure must be incorporated.
- (2) For more information about traditional and new thermal metrics, see the *IC Package Thermal Metrics* application report, [SPRA953](#).

## 7.5 Electrical Characteristics

$V_I = 14\text{ V}$ ,  $1\text{ m}\Omega < \text{ESR} < 20\ \Omega$ ,  $T_J = -40^\circ\text{C}$  to  $150^\circ\text{C}$  unless otherwise stated

PARAMETER		TEST CONDITIONS	MIN	TYP	MAX	UNIT
<b>SUPPLY VOLTAGE AND CURRENT (<math>V_{IN}</math>)</b>						
$V_I$	Input voltage	Fixed 3.3-V output, $I_O = 0$ to 450 mA	4		40	V
		Fixed 5-V output, $I_O = 0$ to 450 mA	5.5		40	
		Adjustable output, $V_O \leq 3.5\text{ V}$ , $I_O = 0$ to 450 mA	4		40	
		Adjustable output, $V_O \geq 3.5\text{ V}$ , $I_O = 0$ to 450 mA	$V_O + 0.5$		40	
$I_Q$	Quiescent current	$V_I = 5.5$ to 40 V (fixed 5 V), 4 to 40 V (fixed 3.3 V), EN = ON, $I_O = 0.2\text{ mA}$		15	25	$\mu\text{A}$
		$V_I = 4$ to 40 V (adjustable version, $V_O = 1.5\text{ V}$ ), EN = ON, $I_O = 0.2\text{ mA}$		15	25	
		$V_I = 18.5$ to 40 V (Adjustable version, $V_O = 18\text{ V}$ ), EN = ON, $I_O = 0.2\text{ mA}$		25	35	
$I_{\text{Sleep}}$	Input sleep current	NO load current and EN = OFF			4	$\mu\text{A}$
$I_{\text{EN}}$	EN terminal current	EN = 40 V			1	$\mu\text{A}$
$V_{\text{bg}}$	Band gap	Reference voltage for ADJ	-2%	1.233	2%	V
$V_{\text{INUVLO}}$	Undervoltage detection	Ramp $V_I$ down until output is turned OFF			2.6	V
$\text{UVLO}_{\text{Hys}}$	Undervoltage detection hysteresis			1		V
<b>ENABLE INPUT (EN)</b>						
$V_{\text{IL}}$	Logic input low level		0		0.4	V
$V_{\text{IH}}$	Logic input high level		1.7			V
<b>REGULATED OUTPUT (<math>V_{\text{OUT}}</math>)</b>						
$V_O$	Regulated output <sup>(1)</sup>	$V_I = V_O + 0.5$ to 40 V and $V_I \geq 4\text{ V}$ , $I_O = 0$ to 450 mA	-2%		2%	
$\Delta V_{O(\Delta V)}$	Line regulation	$V_I = V_O + 1$ to 40 V and $V_I \geq 4\text{ V}$ , $I_O = 100\text{ mA}$ , $\Delta V_O$			10	mV
$\Delta V_{O(\Delta I)}$	Load regulation	$I_O = 1$ to 450 mA, $\Delta V_O$			10	mV
$V_{\text{dropout}}$	Dropout voltage	$V_I - V_O$ , $I_O = 400\text{ mA}$		240	450	mV
		$V_I - V_O$ , $I_O = 200\text{ mA}$		160	300	
$I_O$	Output current	$V_O$ in regulation	0		450	mA
$I_{\text{reg-CL}}$	Output current-limit	$V_O$ short to ground	140		360	mA
		$V_O = V_O$ typical $\times 0.9$	470		850	
PSRR	Power-supply ripple rejection <sup>(2)</sup>	$I_L = 100\text{ mA}$ , $C_O = 22\ \mu\text{F}$	Freq = 100 Hz	60		dB
			Freq = 100 kHz	40		
<b>RESET</b>						
$V_{\text{OL}}$	Reset pulled low	$I_{\text{OL}} = 0.5\text{ mA}$			0.4	V
$I_{\text{OH}}$	Reset pulled $V_{\text{OUT}}$ through 10-k resistor	Leakage current			1	$\mu\text{A}$
$V_{\text{TH-(POR)}}$	Power-On-Reset threshold	$V_O$ power-up set tolerance	89.6	91.6	93.6	% of $V_{\text{OUT}}$
$V_{\text{hys}}$	Hysteresis	$V_O$ power-down set tolerance		2		% of $V_{\text{OUT}}$
<b>RESET DELAY</b>						
$I_{\text{Chg}}$	Delay capacitor charging current	$R_{\text{delay}} = 0\text{ V}$	6	9.5	14	$\mu\text{A}$
$V_{\text{th}}$	Threshold to release RESET high			1		V
<b>OPERATING TEMPERATURE RANGE</b>						
$T_J$	Junction temperature		-40		150	$^\circ\text{C}$
$T_{\text{sd}}$	Junction shutdown temperature			175		$^\circ\text{C}$
$T_{\text{hys}}$	Hysteresis of thermal shutdown			24		$^\circ\text{C}$

(1) External resistor divider variation is not considered.

(2) Design information — Not tested, ensured by characterization

## 7.6 Timing Requirements

		MIN	TYP	MAX	UNIT
<b>TIMING FOR RESET</b>					
$t_{POR}$	Power On Reset Delay	Where C = delay-capacitor value capacitance, C = 100 nF <sup>(1)</sup>		10.5	ms
$t_{POR-fixed}$	Power On Reset Delay	100	325	550	$\mu$ s
$t_{Deglitch}$	Reset deglitch time	55	180	420	$\mu$ s

(1) This information only will NOT be tested in production. The equation is based on:  
 $(C \times 1) / (9.5 \times 10^{-6}) = t_{Delay}$  (delay time)

Where

- C = delay capacitor value capacitance
- C range = 100 pf to 500 nF

## 7.7 Typical Characteristics

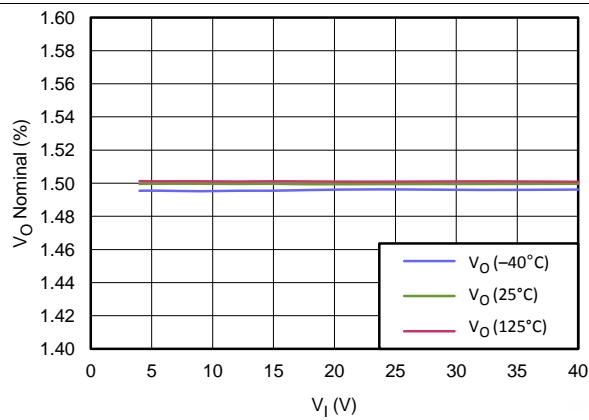

**Figure 1. Line Regulation**  
 (V<sub>O</sub> = 1.5 V, I<sub>L</sub> = 100 mA)

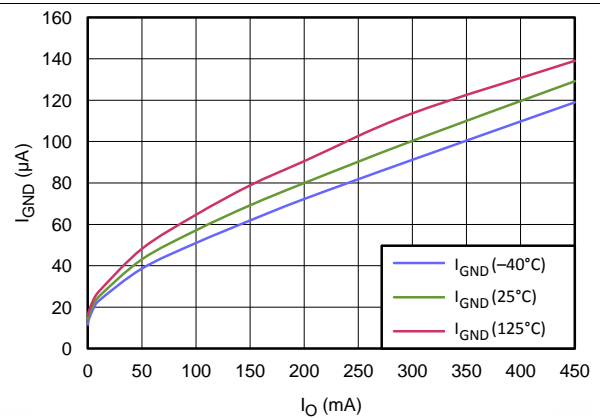

**Figure 2. Ground Current vs Output Current**  
 (V<sub>I</sub> = 14 V, V<sub>O</sub> = 1.5 V)

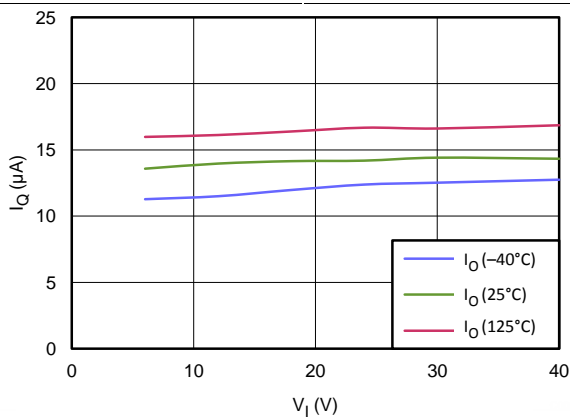

**Figure 3. Quiescent Current vs Input Voltage**  
 (V<sub>O</sub> = 1.5 V)

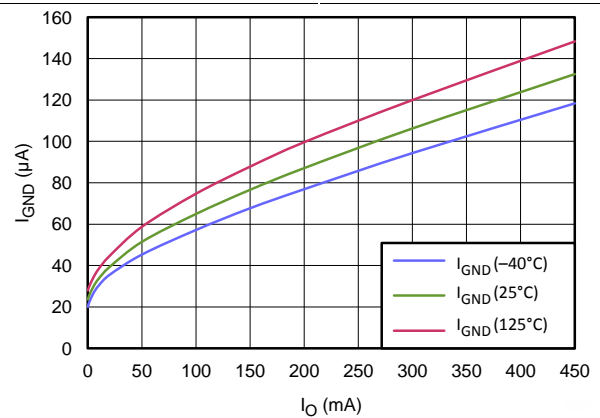

**Figure 4. Ground Current vs Output Current**  
 (V<sub>I</sub> = 24 V, V<sub>O</sub> = 18 V)

Typical Characteristics (continued)

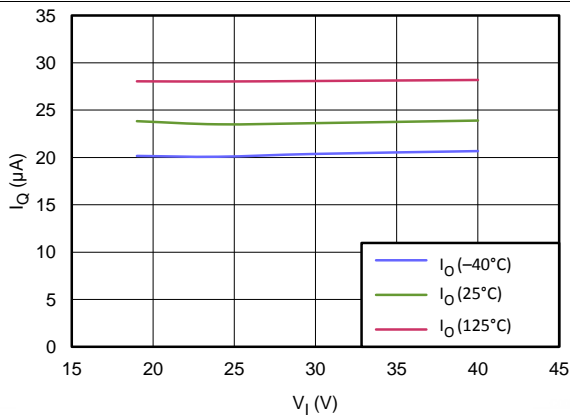

Figure 5. Quiescent Current vs Input Voltage ( $V_O = 18\text{ V}$ )

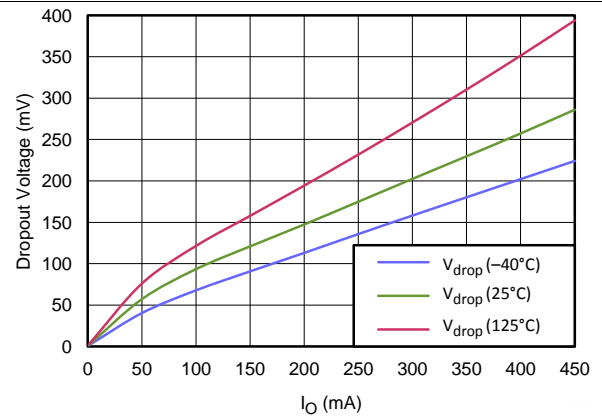

Figure 6. Dropout Voltage vs Output Current

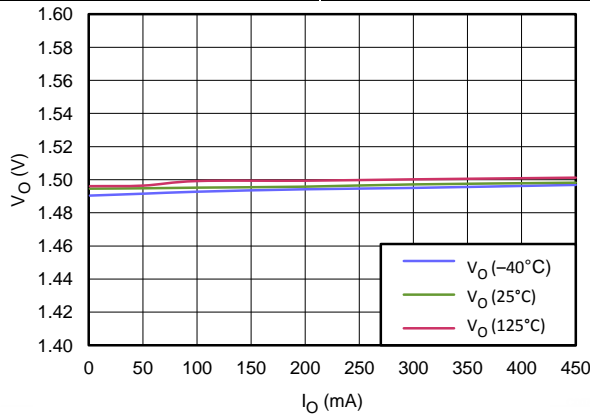

Figure 7. Load Regulation ( $V_I = 14\text{ V}$ ,  $V_O = 1.5\text{ V}$ )

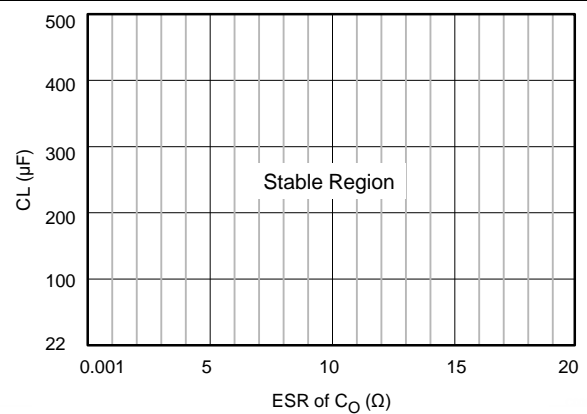

Figure 8. ESR Stability vs Load Capacitance ( $V_O \leq 2.5\text{ V}$ )

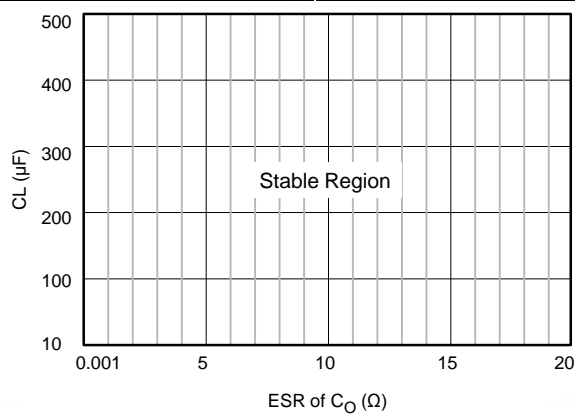

Figure 9. ESR Stability vs Load Capacitance ( $V_O \geq 2.5\text{ V}$ )

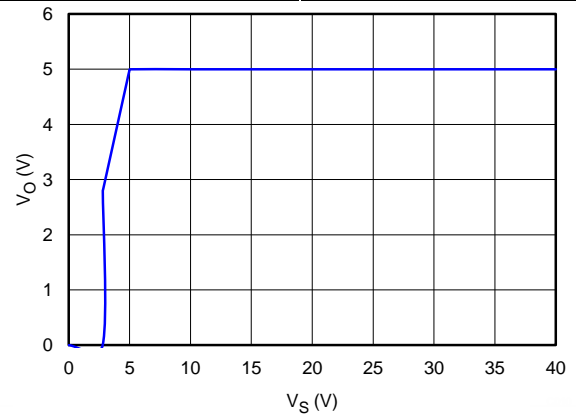
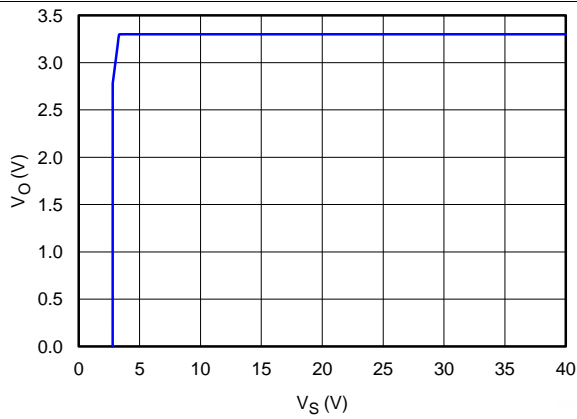
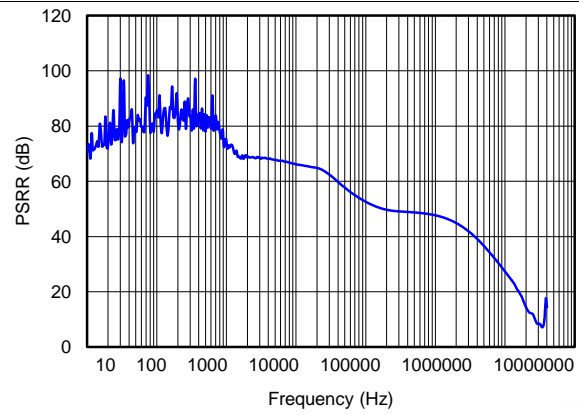

Figure 10. Output Voltage vs Supply Voltage (Fixed 5-V Version,  $I_L = 0$ )

**Typical Characteristics (continued)**



**Figure 11. Output Voltage vs Supply Voltage  
(Fixed 3.3-V Version,  $I_L = 0$ )**



**Figure 12. Power-Supply Rejection Ratio vs Frequency  
( $V_I = 14$  V,  $C_O = 47$   $\mu$ F,  $I_L = 25$  mA)**

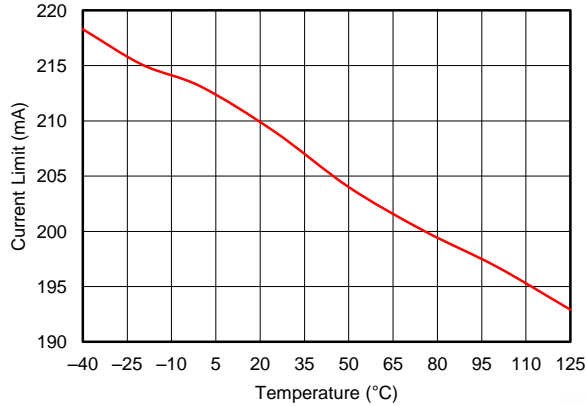

**Figure 13. Short to GND Current-Limit vs Temperature**

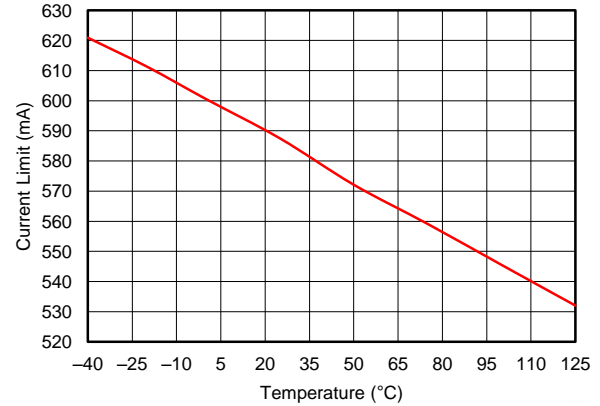

**Figure 14. Current-Limit vs Temperature**

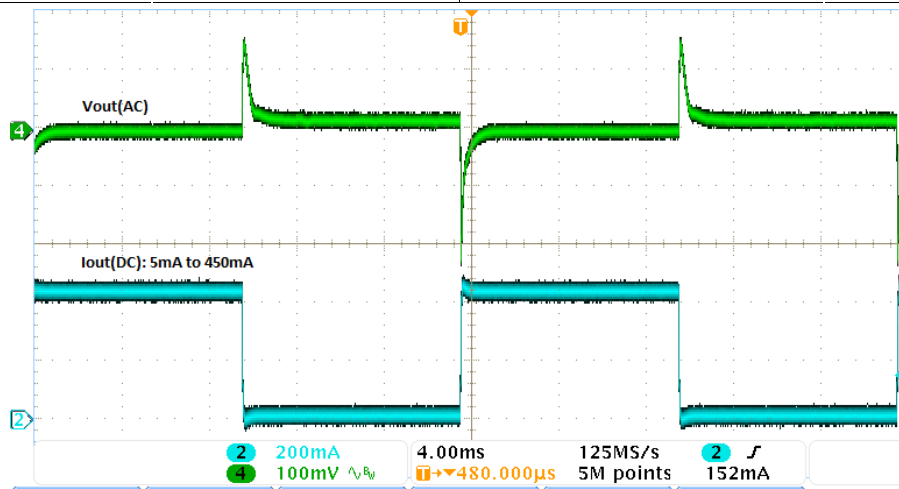

**Figure 15. Load Transient  
10- $\mu$ F Ceramic Output Capacitor**

## 8 Detailed Description

### 8.1 Overview

The TPS7B67xx-Q1 family of devices is an low-dropout linear regulator combined with an enable and reset function. The power-on-reset initializes when the output voltage,  $V_O$ , exceeds 91.6% of the target value. The power-on reset delay is a function of the value set by an external capacitor on the DELAY terminal before releasing the RST terminal high.

### 8.2 Functional Block Diagram

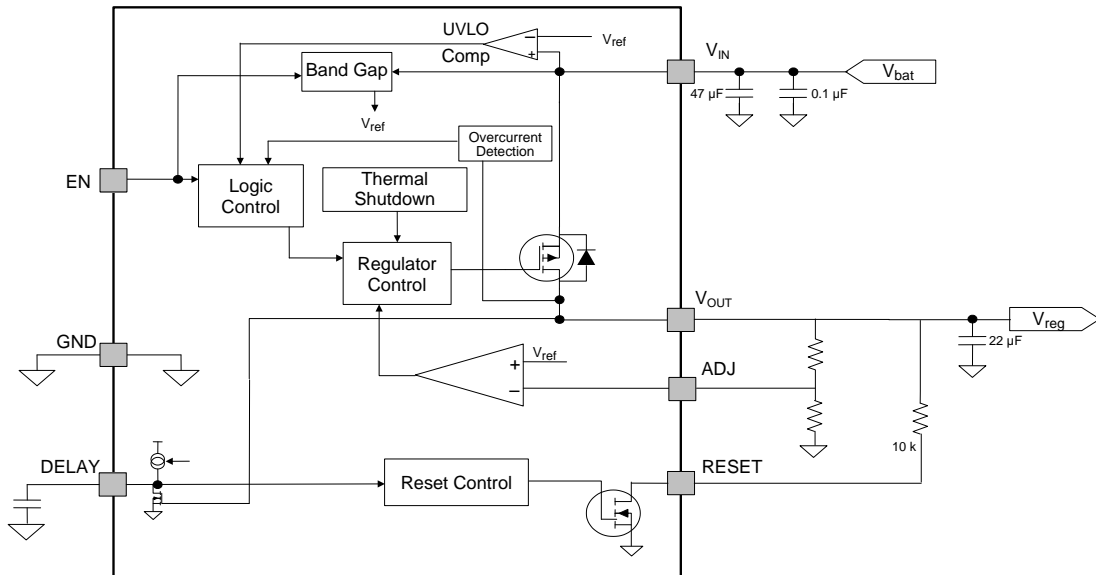

Figure 16. TPS7B6701-Q1 Functional Block Diagram

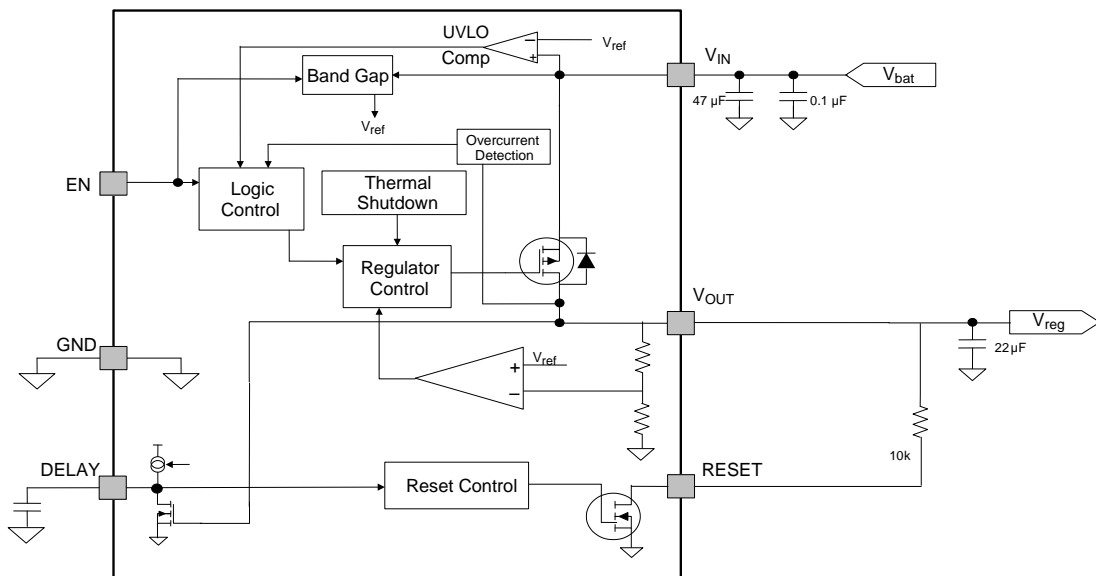

Figure 17. TPS7B6733-Q1 and TPS7B6750-Q1 Functional Block Diagram

## 8.3 Feature Description

### 8.3.1 Enable (EN)

The enable terminal is a high-voltage-tolerant terminal. A high input on EN activates the device and turns on the regulator. For self-bias applications, connect this input to the  $V_{IN}$  terminal.

### 8.3.2 Regulated Output ( $V_{OUT}$ )

The  $V_{OUT}$  terminal is the regulated output based on the required voltage. The output has current limitation. During initial power up, the regulator has a soft start incorporated to control the initial current through the pass element.

In the event that the regulator drops out of regulation, the output tracks the input minus a drop based on the load current. When the input voltage drops below the UVLO threshold, the regulator shuts down until the input voltage recovers above the minimum start-up level.

### 8.3.3 Power-On-Reset (RESET)

The power-on-reset is an output with an external pullup resistor to the regulated supply. The reset output remains low until the regulated  $V_O$  exceeds approximately 91.6% of the set value and the power-on-reset delay has expired. The regulated output falling below the 89.6% level asserts this output low after a short de-glitch time of approximately 180  $\mu$ s (typical).

### 8.3.4 Reset Delay Timer (DELAY)

An external capacitor on this terminal sets the timer delay before the reset terminal is asserted high. The constant output current charges an external capacitor until the voltage exceeds a threshold to trip an internal comparator. If this terminal is open, the default delay time is 325  $\mu$ s (typical).

The reset pulse delay time  $t_d$ , is defined with the charge time of an external capacitor DELAY (see [Equation 1](#)).

$$t_d = \frac{C_{DELAY} \times 1 V}{9.5 \mu A} \quad (1)$$

The power-on-reset initializes when  $V_O$  exceeds 91.6% of the programmed value. The power-on-reset delay is a function of the value set by an external capacitor on the DELAY terminal before the RESET terminal is released high.

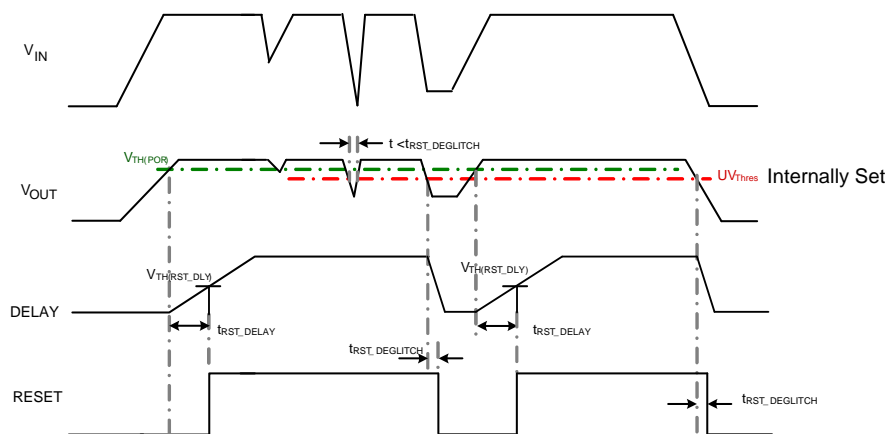

**Figure 18. Conditions to Activate RESET**

## Feature Description (continued)

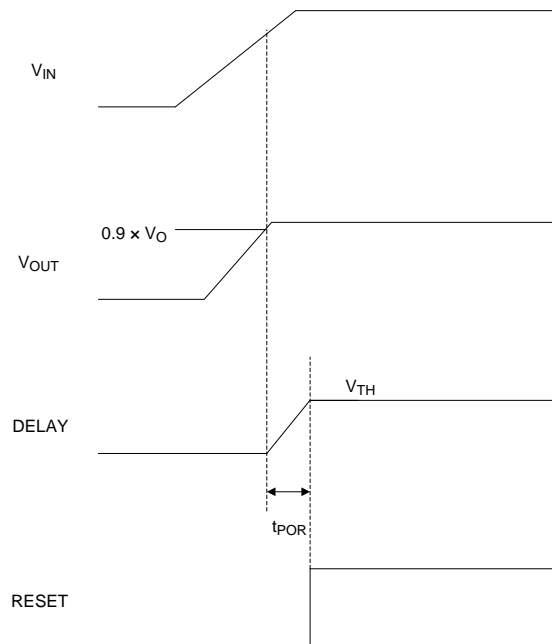

Figure 19. External Programmable-Reset Delay

### 8.3.5 Adjustable Output Voltage (ADJ for TPS7B6701)

An output voltage between 1.5 V and 18 V can be selected by using the external resistor dividers. Use Equation 2 to calculate the output voltage, where  $V_{ADJ} = 1.233$  V. In order to avoid a large leakage current and to prevent a divider error, the value of  $(R1 + R2)$  must be between 10 k and 100 k $\Omega$ .

$$V_O = V_{ADJ} \times \left(1 + \frac{R2}{R1}\right) \quad (2)$$

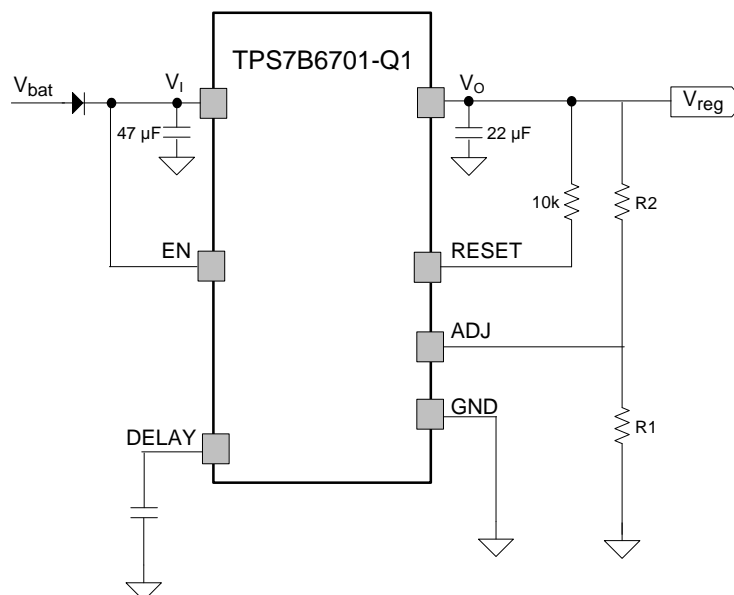

Figure 20. External Feedback Resistor Divider

## Feature Description (continued)

### 8.3.6 Undervoltage Shutdown

The TPS7B67xx-Q1 family of devices has an internally-fixed undervoltage shutdown threshold. Undervoltage shutdown activates when the input voltage on  $V_{IN}$  drops below  $V_{INUVLO}$ . This activation ensures the regulator is not latched into an unknown state during low-input supply voltage. If the input voltage has a negative transient that drops below the UVLO threshold and recovers, the regulator shuts down and powers up similar to a typical power-up sequence when the input voltage is above the required levels.

### 8.3.7 Thermal Shutdown

These devices incorporate a thermal shutdown (TSD) circuit as a protection from overheating. For continuous standard operation, the junction temperature must not exceed the TSD trip-point. If the junction temperature exceeds the TSD trip-point, the output turns off. When the junction temperature falls below the TSD trip-point minus TSD hysteresis, the output turns on again.

### 8.3.8 Thermal Protection

Thermal protection disables the output when the junction temperature rises to approximately 175°C which allows the device to cool. When the junction temperature cools to approximately 150°C, the output circuitry enables. Based on power dissipation, thermal resistance, and ambient temperature, the thermal protection circuit may cycle on and off. This cycling limits the dissipation of the regulator and protects it from damage as a result of overheating.

The internal protection circuitry of the TPS7B67xx-Q1 device has been designed to protect against overload conditions. The circuitry was not intended to replace proper heat-sinking. Continuously running the TPS7B67xx-Q1 device into thermal shutdown degrades device reliability.

## 8.4 Device Functional Modes

### 8.4.1 Operation With $V_{IN} < 4$ V

The devices operate with input voltages above 4 V. The maximum UVLO voltage is 2.6 V and operates at input voltage above 4 V. The devices can also operate at lower input voltages; no minimum UVLO voltage is specified. At input voltages below the actual UVLO voltage, the devices do not operate.

### 8.4.2 Operation With EN Control

The enable rising edge threshold voltage is 1.7 V (maximum), with the EN terminal is held above that voltage and the input voltage is above the 4 V, the device becomes active. The enable falling edge is 0.4 V (minimum), with the EN terminal is held below that voltage the device is disabled, the IC quiescent current is reduced in this state.

## 9 Application and Implementation

### 9.1 Application Information

Figure 21 and Figure 22 show typical application circuits for the TPS7B6701-Q1 device and the TPS7B6733-Q1 and TPS7B6750-Q1 device respectively. Based on the end-application, different values of external components can be used. An application can require a larger output capacitor during fast load steps in order to prevent a reset from occurring. TI recommends a low-ESR ceramic capacitor with a dielectric of type X5R or X7R for better load transient response.

### 9.2 Typical Application

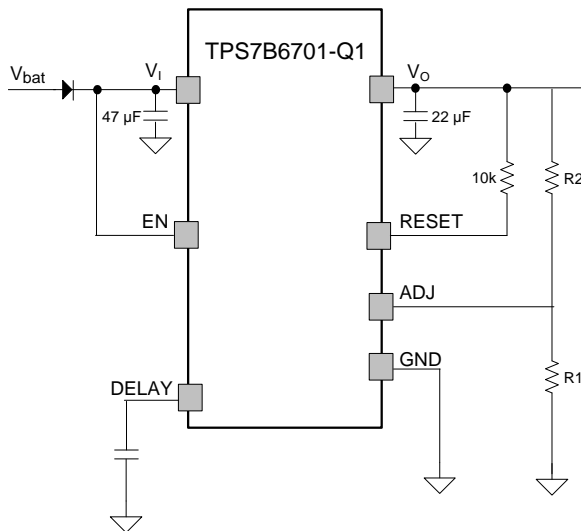

Figure 21. Typical Application Schematic for TPS7B6701-Q1

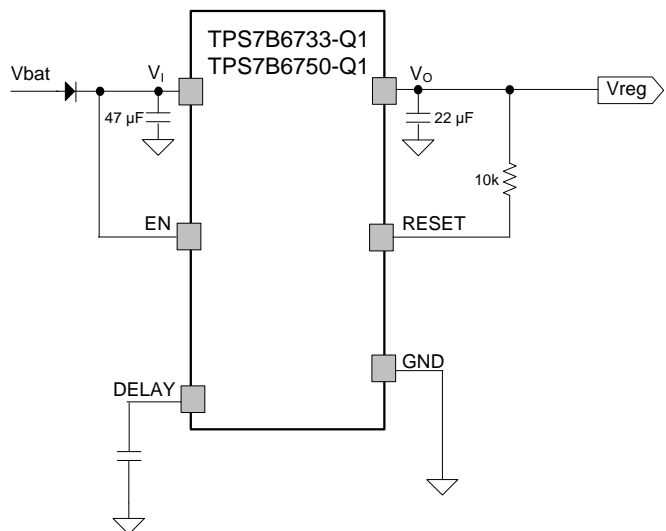

Figure 22. Typical Application Schematic for TPS7B6733-Q1 and TPS7B6750-Q1

#### 9.2.1 Design Requirements

For this design example, use the parameters listed in Table 1.

Table 1. Design Parameters

DESIGN PARAMETER	EXAMPLE VALUE
Input voltage range	4 to 40 V
Output voltage	1.5 to 18 V
Output current rating	450 mA
Output capacitor range	10 to 500 µF
Output capacitor ESR range	1 mΩ to 20 Ω
DELAY capacitor range	100 pF to 500 nF

#### 9.2.2 Detailed Design Procedure

To begin the design process, determine the following:

- Input voltage range
- Output voltage
- Output current rating
- Output capacitor
- Power-up reset delay time

### 9.2.2.1 Power Dissipation and Thermal Considerations

Device power dissipation is calculated with Equation 3.

$$P_D = I_O \times (V_I - V_O) + I_Q \times V_I$$

where

- $P_D$  = continuous power dissipation
- $I_O$  = output current
- $V_I$  = input voltage
- $V_O$  = output voltage

(3)

As  $I_Q \ll I_O$ , the term  $I_Q \times V_I$  in Equation 3 can be ignored.

For a device under operation at a given ambient air temperature ( $T_A$ ), calculate the junction temperature ( $T_J$ ) with Equation 4.

$$T_J = T_A + (\theta_{JA} \times P_D)$$

where

- $\theta_{JA}$  = junction-to-ambient air thermal impedance

(4)

A rise in junction temperature because of power dissipation can be calculated with Equation 5.

$$\Delta T = T_J - T_A = (\theta_{JA} \times P_D)$$

(5)

For a given maximum junction temperature ( $T_{JM}$ ), the maximum ambient air temperature ( $T_{AM}$ ) at which the device can operate is calculated with Equation 6.

$$T_{AM} = T_{JM} - (\theta_{JA} \times P_D)$$

(6)

### 9.2.3 Application Curves

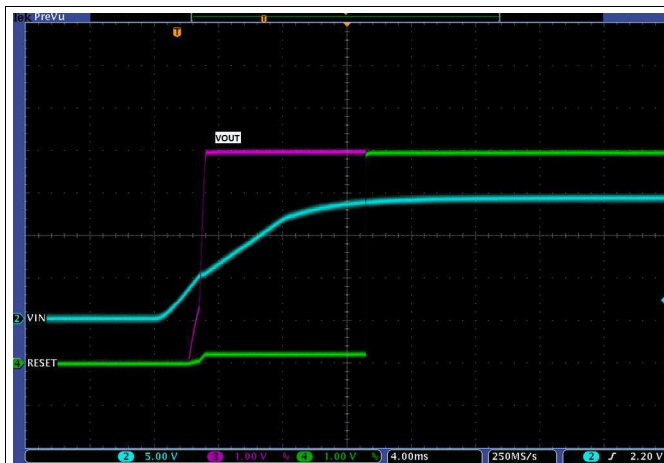

Load = 200 mA

$C_{IN} = C_{OUT} = 47 \mu F$

Figure 23. TPS7B6750-Q1 Power-Up Waveform



Load = 200 mA

$C_{IN} = C_{OUT} = 47 \mu F$

Figure 24. TPS7B6750-Q1 Power-Down Waveform

## 10 Power Supply Recommendations

The device is designed to operate from an input voltage supply range between 4 V and 40 V. This input supply must be well regulated. If the input supply is located more than a few inches from the TPS7B67xx-Q1 device, an electrolytic capacitor with a value of 47  $\mu$ F and a ceramic bypass capacitor are recommended to add at the input.

## 11 Layout

### 11.1 Layout Guidelines

#### 11.1.1 Enhanced Thermal Pad

For the PWP package, TI recommends to layout an enhanced thermal pad on the board in order to realize better thermal impedance as shown in [Figure 25](#). No extra board size is required and the standard operation is not influenced by this layout.

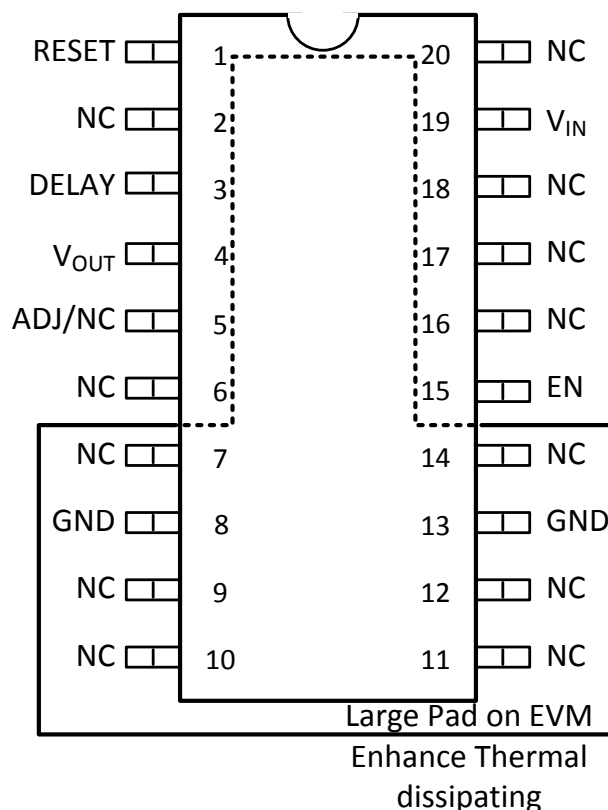

**Figure 25. Thermally Enhanced Layout for the PWP Package (TPS7B6701-Q1)**

#### 11.1.2 Package Mounting

Solder-pad footprint recommendations for the TPS7B67xx-Q1 devices are available at the end of this data sheet and at [www.ti.com](http://www.ti.com).

#### 11.1.3 Board Layout Recommendations to Improve PSRR and Noise Performance

- To improve AC performance such as PSRR, output noise, and transient response, TI recommends to design the board with separate ground planes for  $V_{IN}$  and  $V_{OUT}$ , with each ground plane connected only at the GND terminal of the device. In addition, the ground connection for the output capacitor must connect directly to the GND terminal of the device.
- Equivalent series inductance (ESL) and ESR must be minimized in order to maximize performance and ensure stability. Every capacitor must be placed as close to the device as possible and on the same side of the PCB as the regulator.

## Layout Guidelines (continued)

- Do not place any of the capacitors on the opposite side of the PCB from where the regulator is installed. The use of vias and long traces is strongly discouraged because of the negative impact on system performance. Vias and long traces can also cause instability.
- If possible, and to ensure the maximum performance listed in this data sheet, use the same layout pattern used for TPS7B67xx-Q1 evaluation board, available at [www.ti.com](http://www.ti.com).

### 11.1.4 Additional Layout Considerations

Because of the high impedance of the ADJ terminal, the regulator is sensitive to parasitic capacitances that can couple undesirable signals from nearby components (especially from logic and digital ICs, such as microcontrollers and microprocessors). These capacitive-coupled signals can produce undesirable output-voltage transients. If undesirable output-voltage transients occur, TI recommends to use a fixed-voltage version of the TPS7B67xx-Q1 devices, or to isolate the ADJ node by flooding the local PCB area with ground-to-plane copper in order to minimize any undesirable signal coupling.

## 11.2 Layout Example

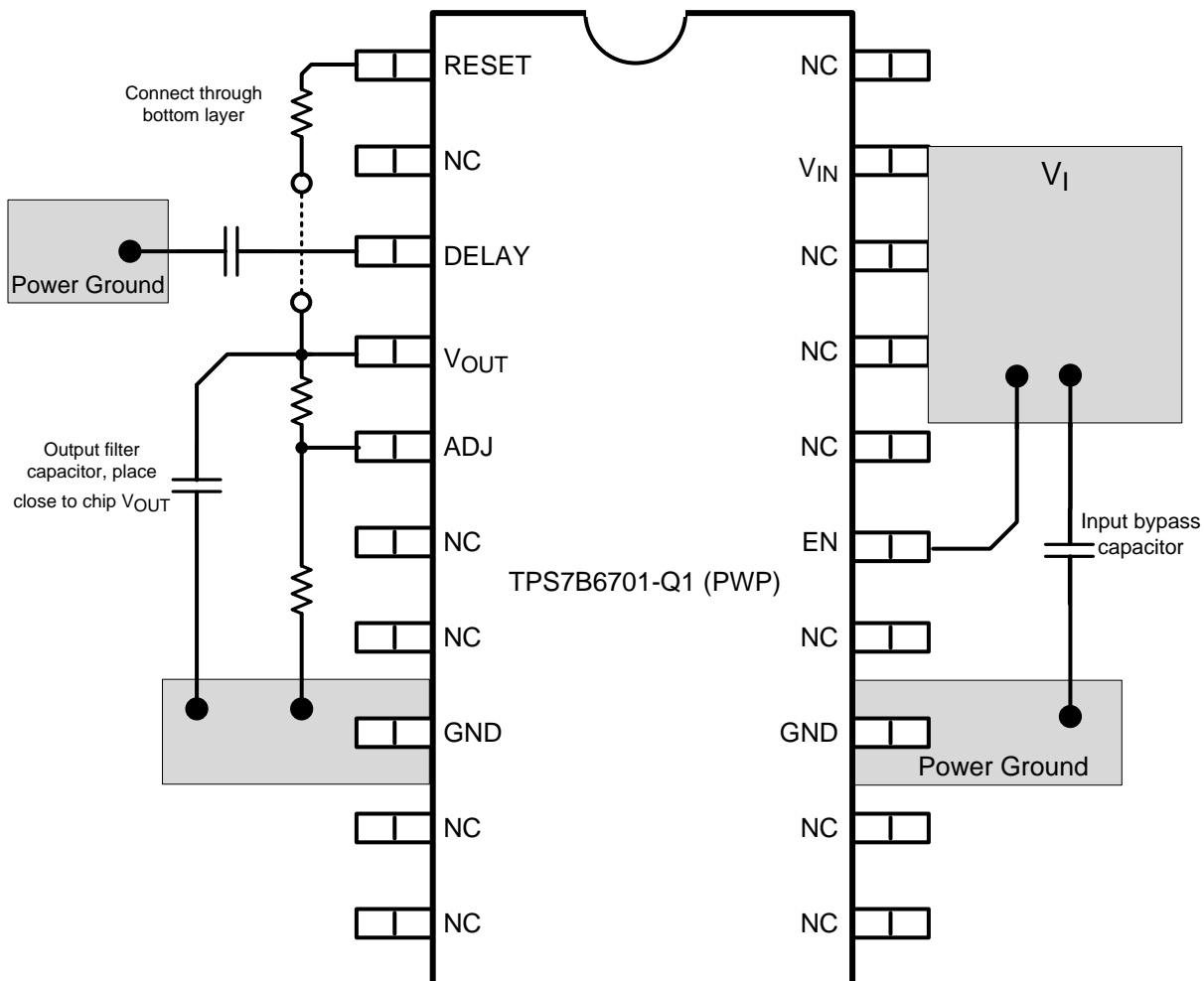

Figure 26. TPS7B6701-Q1 Layout Example

## 12 Device and Documentation Support

### 12.1 Related Links

The table below lists quick access links. Categories include technical documents, support and community resources, tools and software, and quick access to sample or buy.

**Table 2. Related Links**

PARTS	PRODUCT FOLDER	SAMPLE & BUY	TECHNICAL DOCUMENTS	TOOLS & SOFTWARE	SUPPORT & COMMUNITY
TPS7B6701-Q1	<a href="#">Click here</a>	<a href="#">Click here</a>	<a href="#">Click here</a>	<a href="#">Click here</a>	<a href="#">Click here</a>
TPS7B6733-Q1	<a href="#">Click here</a>	<a href="#">Click here</a>	<a href="#">Click here</a>	<a href="#">Click here</a>	<a href="#">Click here</a>
TPS7B6750-Q1	<a href="#">Click here</a>	<a href="#">Click here</a>	<a href="#">Click here</a>	<a href="#">Click here</a>	<a href="#">Click here</a>
TPS7B6750A-Q1	<a href="#">Click here</a>	<a href="#">Click here</a>	<a href="#">Click here</a>	<a href="#">Click here</a>	<a href="#">Click here</a>
TPS7B6750B-Q1	<a href="#">Click here</a>	<a href="#">Click here</a>	<a href="#">Click here</a>	<a href="#">Click here</a>	<a href="#">Click here</a>

### 12.2 Trademarks

PowerPAD is a trademark of Texas Instruments.

### 12.3 Electrostatic Discharge Caution



This integrated circuit can be damaged by ESD. Texas Instruments recommends that all integrated circuits be handled with appropriate precautions. Failure to observe proper handling and installation procedures can cause damage.

ESD damage can range from subtle performance degradation to complete device failure. Precision integrated circuits may be more susceptible to damage because very small parametric changes could cause the device not to meet its published specifications.

### 12.4 Glossary

[SLYZ022](#) — *TI Glossary*.

This glossary lists and explains terms, acronyms and definitions.

## 13 Mechanical, Packaging, and Orderable Information

The following pages include mechanical packaging and orderable information. This information is the most current data available for the designated devices. This data is subject to change without notice and revision of this document. For browser-based versions of this data sheet, refer to the left-hand navigation.

**PACKAGING INFORMATION**

Orderable Device	Status (1)	Package Type	Package Drawing	Pins	Package Qty	Eco Plan (2)	Lead/Ball Finish (6)	MSL Peak Temp (3)	Op Temp (°C)	Device Marking (4/5)	Samples
TPS7B6701QPWPRQ1	ACTIVE	HTSSOP	PWP	20	2000	Green (RoHS & no Sb/Br)	CU NIPDAU	Level-3-260C-168 HR	-40 to 125	7B6701	Samples
TPS7B6733QPWPRQ1	PREVIEW	HTSSOP	PWP	20	1	TBD	Call TI	Call TI	-40 to 125		
TPS7B6750QPWPRQ1	PREVIEW	HTSSOP	PWP	20	1	TBD	Call TI	Call TI	-40 to 125		

(1) The marketing status values are defined as follows:

**ACTIVE:** Product device recommended for new designs.

**LIFEBUY:** TI has announced that the device will be discontinued, and a lifetime-buy period is in effect.

**NRND:** Not recommended for new designs. Device is in production to support existing customers, but TI does not recommend using this part in a new design.

**PREVIEW:** Device has been announced but is not in production. Samples may or may not be available.

**OBSOLETE:** TI has discontinued the production of the device.

(2) Eco Plan - The planned eco-friendly classification: Pb-Free (RoHS), Pb-Free (RoHS Exempt), or Green (RoHS & no Sb/Br) - please check <http://www.ti.com/productcontent> for the latest availability information and additional product content details.

**TBD:** The Pb-Free/Green conversion plan has not been defined.

**Pb-Free (RoHS):** TI's terms "Lead-Free" or "Pb-Free" mean semiconductor products that are compatible with the current RoHS requirements for all 6 substances, including the requirement that lead not exceed 0.1% by weight in homogeneous materials. Where designed to be soldered at high temperatures, TI Pb-Free products are suitable for use in specified lead-free processes.

**Pb-Free (RoHS Exempt):** This component has a RoHS exemption for either 1) lead-based flip-chip solder bumps used between the die and package, or 2) lead-based die adhesive used between the die and leadframe. The component is otherwise considered Pb-Free (RoHS compatible) as defined above.

**Green (RoHS & no Sb/Br):** TI defines "Green" to mean Pb-Free (RoHS compatible), and free of Bromine (Br) and Antimony (Sb) based flame retardants (Br or Sb do not exceed 0.1% by weight in homogeneous material)

(3) MSL, Peak Temp. - The Moisture Sensitivity Level rating according to the JEDEC industry standard classifications, and peak solder temperature.

(4) There may be additional marking, which relates to the logo, the lot trace code information, or the environmental category on the device.

(5) Multiple Device Markings will be inside parentheses. Only one Device Marking contained in parentheses and separated by a "~" will appear on a device. If a line is indented then it is a continuation of the previous line and the two combined represent the entire Device Marking for that device.

(6) Lead/Ball Finish - Orderable Devices may have multiple material finish options. Finish options are separated by a vertical ruled line. Lead/Ball Finish values may wrap to two lines if the finish value exceeds the maximum column width.

**Important Information and Disclaimer:** The information provided on this page represents TI's knowledge and belief as of the date that it is provided. TI bases its knowledge and belief on information provided by third parties, and makes no representation or warranty as to the accuracy of such information. Efforts are underway to better integrate information from third parties. TI has taken and continues to take reasonable steps to provide representative and accurate information but may not have conducted destructive testing or chemical analysis on incoming materials and chemicals. TI and TI suppliers consider certain information to be proprietary, and thus CAS numbers and other limited information may not be available for release.

In no event shall TI's liability arising out of such information exceed the total purchase price of the TI part(s) at issue in this document sold by TI to Customer on an annual basis.

## TAPE AND REEL INFORMATION



### QUADRANT ASSIGNMENTS FOR PIN 1 ORIENTATION IN TAPE



\*All dimensions are nominal

Device	Package Type	Package Drawing	Pins	SPQ	Reel Diameter (mm)	Reel Width W1 (mm)	A0 (mm)	B0 (mm)	K0 (mm)	P1 (mm)	W (mm)	Pin1 Quadrant
TPS7B6701QPWPRQ1	HTSSOP	PWP	20	2000	330.0	16.4	6.95	7.1	1.6	8.0	16.0	Q1

TAPE AND REEL BOX DIMENSIONS



\*All dimensions are nominal

Device	Package Type	Package Drawing	Pins	SPQ	Length (mm)	Width (mm)	Height (mm)
TPS7B6701QPWRQ1	HTSSOP	PWP	20	2000	367.0	367.0	38.0

# MECHANICAL DATA

PWP (R-PDSO-G20)

PowerPAD™ PLASTIC SMALL OUTLINE



4073225-4/1 05/11

- NOTES:
- All linear dimensions are in millimeters.
  - This drawing is subject to change without notice.
  - Body dimensions do not include mold flash or protrusions. Mold flash and protrusion shall not exceed 0.15 per side.
  - This package is designed to be soldered to a thermal pad on the board. Refer to Technical Brief, PowerPad Thermally Enhanced Package, Texas Instruments Literature No. SLMA002 for information regarding recommended board layout. This document is available at [www.ti.com](http://www.ti.com) <<http://www.ti.com>>.
  - See the additional figure in the Product Data Sheet for details regarding the exposed thermal pad features and dimensions.
  - Falls within JEDEC MO-153

PowerPAD is a trademark of Texas Instruments.

## THERMAL PAD MECHANICAL DATA

### PWP (R-PDSO-G20) PowerPAD™ SMALL PLASTIC OUTLINE

#### THERMAL INFORMATION

This PowerPAD™ package incorporates an exposed thermal pad that is designed to be attached to a printed circuit board (PCB). The thermal pad must be soldered directly to the PCB. After soldering, the PCB can be used as a heatsink. In addition, through the use of thermal vias, the thermal pad can be attached directly to the appropriate copper plane shown in the electrical schematic for the device, or alternatively, can be attached to a special heatsink structure designed into the PCB. This design optimizes the heat transfer from the integrated circuit (IC).

For additional information on the PowerPAD package and how to take advantage of its heat dissipating abilities, refer to Technical Brief, PowerPAD Thermally Enhanced Package, Texas Instruments Literature No. SLMA002 and Application Brief, PowerPAD Made Easy, Texas Instruments Literature No. SLMA004. Both documents are available at [www.ti.com](http://www.ti.com).

The exposed thermal pad dimensions for this package are shown in the following illustration.

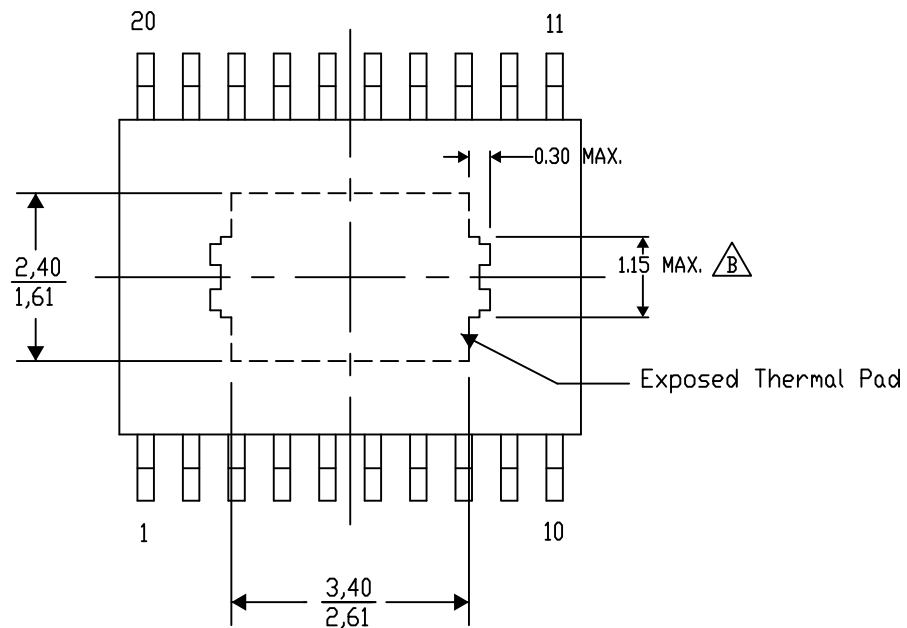

Top View

Exposed Thermal Pad Dimensions

4206332-15/AH 11/13

NOTE: A. All linear dimensions are in millimeters

 Exposed tie strap features may not be present.

PowerPAD is a trademark of Texas Instruments

PWP (R-PDSO-G20)

PowerPAD™ PLASTIC SMALL OUTLINE

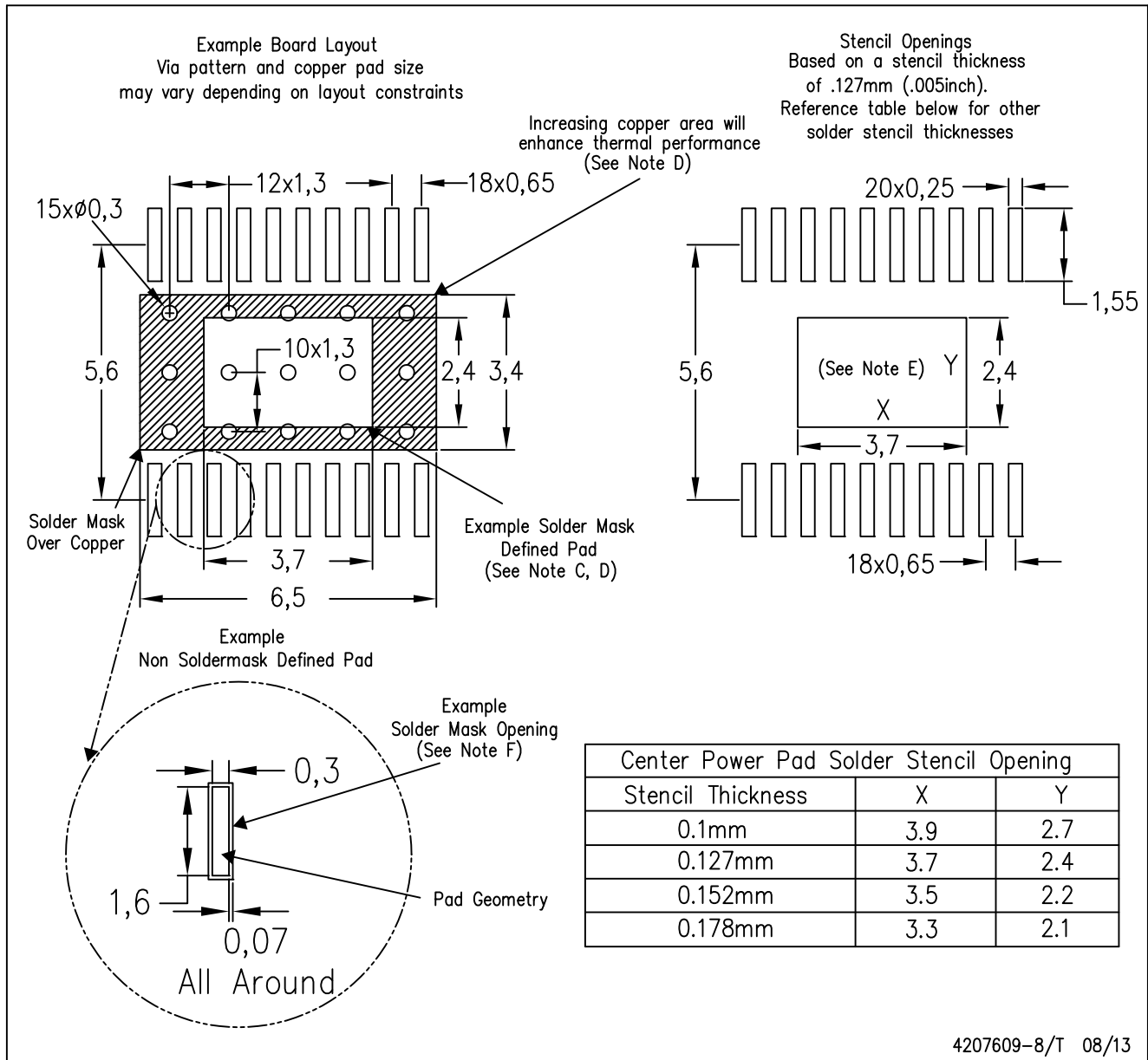

- NOTES:
- All linear dimensions are in millimeters.
  - This drawing is subject to change without notice.
  - Customers should place a note on the circuit board fabrication drawing not to alter the center solder mask defined pad.
  - This package is designed to be soldered to a thermal pad on the board. Refer to Technical Brief, PowerPad Thermally Enhanced Package, Texas Instruments Literature No. SLMA002, SLMA004, and also the Product Data Sheets for specific thermal information, via requirements, and recommended board layout. These documents are available at [www.ti.com](http://www.ti.com) <<http://www.ti.com>>. Publication IPC-7351 is recommended for alternate designs.
  - Laser cutting apertures with trapezoidal walls and also rounding corners will offer better paste release. Customers should contact their board assembly site for stencil design recommendations. Example stencil design based on a 50% volumetric metal load solder paste. Refer to IPC-7525 for other stencil recommendations.
  - Customers should contact their board fabrication site for solder mask tolerances between and around signal pads.

## IMPORTANT NOTICE

Texas Instruments Incorporated and its subsidiaries (TI) reserve the right to make corrections, enhancements, improvements and other changes to its semiconductor products and services per JESD46, latest issue, and to discontinue any product or service per JESD48, latest issue. Buyers should obtain the latest relevant information before placing orders and should verify that such information is current and complete. All semiconductor products (also referred to herein as "components") are sold subject to TI's terms and conditions of sale supplied at the time of order acknowledgment.

TI warrants performance of its components to the specifications applicable at the time of sale, in accordance with the warranty in TI's terms and conditions of sale of semiconductor products. Testing and other quality control techniques are used to the extent TI deems necessary to support this warranty. Except where mandated by applicable law, testing of all parameters of each component is not necessarily performed.

TI assumes no liability for applications assistance or the design of Buyers' products. Buyers are responsible for their products and applications using TI components. To minimize the risks associated with Buyers' products and applications, Buyers should provide adequate design and operating safeguards.

TI does not warrant or represent that any license, either express or implied, is granted under any patent right, copyright, mask work right, or other intellectual property right relating to any combination, machine, or process in which TI components or services are used. Information published by TI regarding third-party products or services does not constitute a license to use such products or services or a warranty or endorsement thereof. Use of such information may require a license from a third party under the patents or other intellectual property of the third party, or a license from TI under the patents or other intellectual property of TI.

Reproduction of significant portions of TI information in TI data books or data sheets is permissible only if reproduction is without alteration and is accompanied by all associated warranties, conditions, limitations, and notices. TI is not responsible or liable for such altered documentation. Information of third parties may be subject to additional restrictions.

Resale of TI components or services with statements different from or beyond the parameters stated by TI for that component or service voids all express and any implied warranties for the associated TI component or service and is an unfair and deceptive business practice. TI is not responsible or liable for any such statements.

Buyer acknowledges and agrees that it is solely responsible for compliance with all legal, regulatory and safety-related requirements concerning its products, and any use of TI components in its applications, notwithstanding any applications-related information or support that may be provided by TI. Buyer represents and agrees that it has all the necessary expertise to create and implement safeguards which anticipate dangerous consequences of failures, monitor failures and their consequences, lessen the likelihood of failures that might cause harm and take appropriate remedial actions. Buyer will fully indemnify TI and its representatives against any damages arising out of the use of any TI components in safety-critical applications.

In some cases, TI components may be promoted specifically to facilitate safety-related applications. With such components, TI's goal is to help enable customers to design and create their own end-product solutions that meet applicable functional safety standards and requirements. Nonetheless, such components are subject to these terms.

No TI components are authorized for use in FDA Class III (or similar life-critical medical equipment) unless authorized officers of the parties have executed a special agreement specifically governing such use.

Only those TI components which TI has specifically designated as military grade or "enhanced plastic" are designed and intended for use in military/aerospace applications or environments. Buyer acknowledges and agrees that any military or aerospace use of TI components which have **not** been so designated is solely at the Buyer's risk, and that Buyer is solely responsible for compliance with all legal and regulatory requirements in connection with such use.

TI has specifically designated certain components as meeting ISO/TS16949 requirements, mainly for automotive use. In any case of use of non-designated products, TI will not be responsible for any failure to meet ISO/TS16949.

### Products

Audio	<a href="http://www.ti.com/audio">www.ti.com/audio</a>
Amplifiers	<a href="http://amplifier.ti.com">amplifier.ti.com</a>
Data Converters	<a href="http://dataconverter.ti.com">dataconverter.ti.com</a>
DLP® Products	<a href="http://www.dlp.com">www.dlp.com</a>
DSP	<a href="http://dsp.ti.com">dsp.ti.com</a>
Clocks and Timers	<a href="http://www.ti.com/clocks">www.ti.com/clocks</a>
Interface	<a href="http://interface.ti.com">interface.ti.com</a>
Logic	<a href="http://logic.ti.com">logic.ti.com</a>
Power Mgmt	<a href="http://power.ti.com">power.ti.com</a>
Microcontrollers	<a href="http://microcontroller.ti.com">microcontroller.ti.com</a>
RFID	<a href="http://www.ti-rfid.com">www.ti-rfid.com</a>
OMAP Applications Processors	<a href="http://www.ti.com/omap">www.ti.com/omap</a>
Wireless Connectivity	<a href="http://www.ti.com/wirelessconnectivity">www.ti.com/wirelessconnectivity</a>

### Applications

Automotive and Transportation	<a href="http://www.ti.com/automotive">www.ti.com/automotive</a>
Communications and Telecom	<a href="http://www.ti.com/communications">www.ti.com/communications</a>
Computers and Peripherals	<a href="http://www.ti.com/computers">www.ti.com/computers</a>
Consumer Electronics	<a href="http://www.ti.com/consumer-apps">www.ti.com/consumer-apps</a>
Energy and Lighting	<a href="http://www.ti.com/energy">www.ti.com/energy</a>
Industrial	<a href="http://www.ti.com/industrial">www.ti.com/industrial</a>
Medical	<a href="http://www.ti.com/medical">www.ti.com/medical</a>
Security	<a href="http://www.ti.com/security">www.ti.com/security</a>
Space, Avionics and Defense	<a href="http://www.ti.com/space-avionics-defense">www.ti.com/space-avionics-defense</a>
Video and Imaging	<a href="http://www.ti.com/video">www.ti.com/video</a>

### TI E2E Community

[e2e.ti.com](http://e2e.ti.com)